

Automatic **fire** suppression **system**



Kitchens

BlazeCut.com

Markets and Product Range

Fire is a risk on equipment and devices; to help control the risk and reduce the likelihood of fire, a BlazeCut system can be installed. A benefit of the system is that it can easily be adapted to your application. Offering 2 distinctly different system configurations; BlazeCut is a specifically designed solution to suppress fires. The BlazeCut system is adaptable to a wide range of applications with benefits to the customer

- Easy to install
- Fast acting
- Compact
- Dependable
- Fully independent



T Series

The system consists of a heat sensitive tube made of special plastic which is closed by a stainless steel fitting on each end. The tube has both storage and detection function which means that the extinguishing agent is stored directly in the tube and no additional storage device like a cylinder is needed.

Typical applications include electrical enclosures or engine compartments of vehicles, machines or pleasure boats. The BlazeCut T Series system is conveniently supplied in a retail box along with the user manual, ties and warning labels.

- Small and flexible
- 10 year working life
- No Cylinder



C Series

BlazeCut provides an automatic fire suppression systems through the use of the "C" Series. The systems are supplied with a choice of FK5-1-12 or HFC-227ea Gaseous clean agents, which are the best choice for protection of sensitive devices, as they leave no residue after extinguishing. Additionally, the agent is completely non-corrosive, electrically non-conductive and safe for people. For applications such as mobile equipment, manufacturing and kitchens, the systems are supplied with the either powder or foam agents. BlazeCut systems are manufactured in two versions: Direct or indirect Low Pressure System.

- Higher volume system
- Tight and confined areas
- Increase configurations and designs



BlazeCut systems are:

- Fully independent and does not require external power or human intervention to work
- Designed to protect and control risks which results in the preservation of life and assets



Overview

The BlazeCut company is a fire suppression system manufacturer and specialist that delivers the latest in technologies. We focus on providing top performing systems manufactured to the highest standards. BlazeCut have improved the way a system can perform and protect you and your valuable assets in a harsh risk environment. With 70 years of industry experience we can offer you peace of mind that the product you buy is made to perform. We monitor and adapt to innovations continuously developing greener technologies that can help a system perform without compromise to the greater environmental impacts.

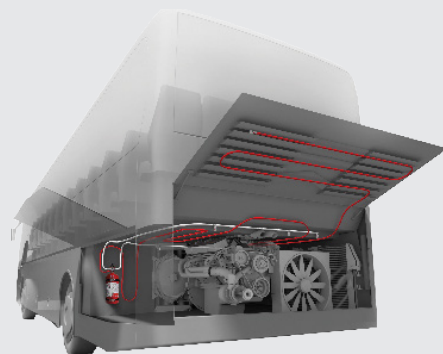

Manufacturing, Testing and Development

With the BlazeCut global head office in Australia, our manufacturing facility in Europe, the fire suppression systems and components are manufactured according to the latest ISO9001, ISO14001, AQAP quality management and environmental standards. All systems are tested at our in-house testing facility as well as by accredited testing institutes. We are committed to customer satisfaction every inquiry is held individually to provide tailor made solution that fit our customer needs. Development continues and BlazeCut prides itself with continuing to innovate and design new products to help monitor and control risk areas.



Global Network

BlazeCut focuses to build a network of distribution partners in the different regions around the world to ensure that the customers get the best level of support possible. BlazeCut has strategically positioned local offices and Sales support personnel around the globe.

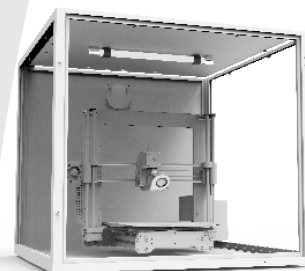

Contact Us

Global Head Office:

BlazeCut Pty Ltd
Sydney, Australia
sales@blazecutgroup.com
+61 2 8006 1300

BlazeCut.com

Regional Locations:

Chile	Indonesia
Russia	Singapore
Spain	Sweden
Thailand	Turkey
Spain	UK
USA	

Dealers/Distributor:

BlazeCut has a global network of dealers and distributors. To find your nearest stockist or to become a dealer please contact BlazeCut

Manufacturing:

BlazeCut s.r.o., Bernolákovo, Slovakia

