

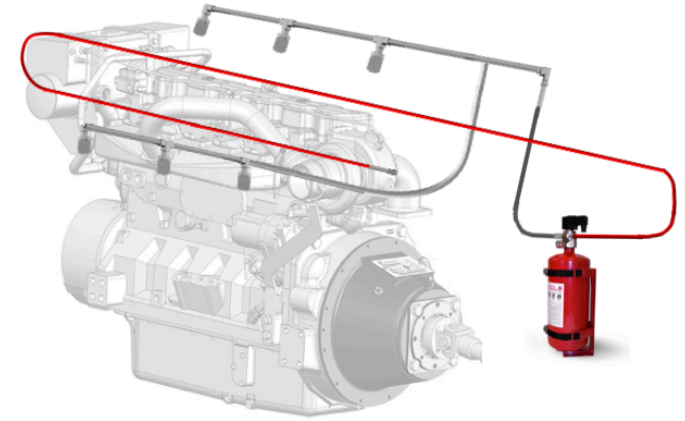

Automatic/Manual Fire Suppression System

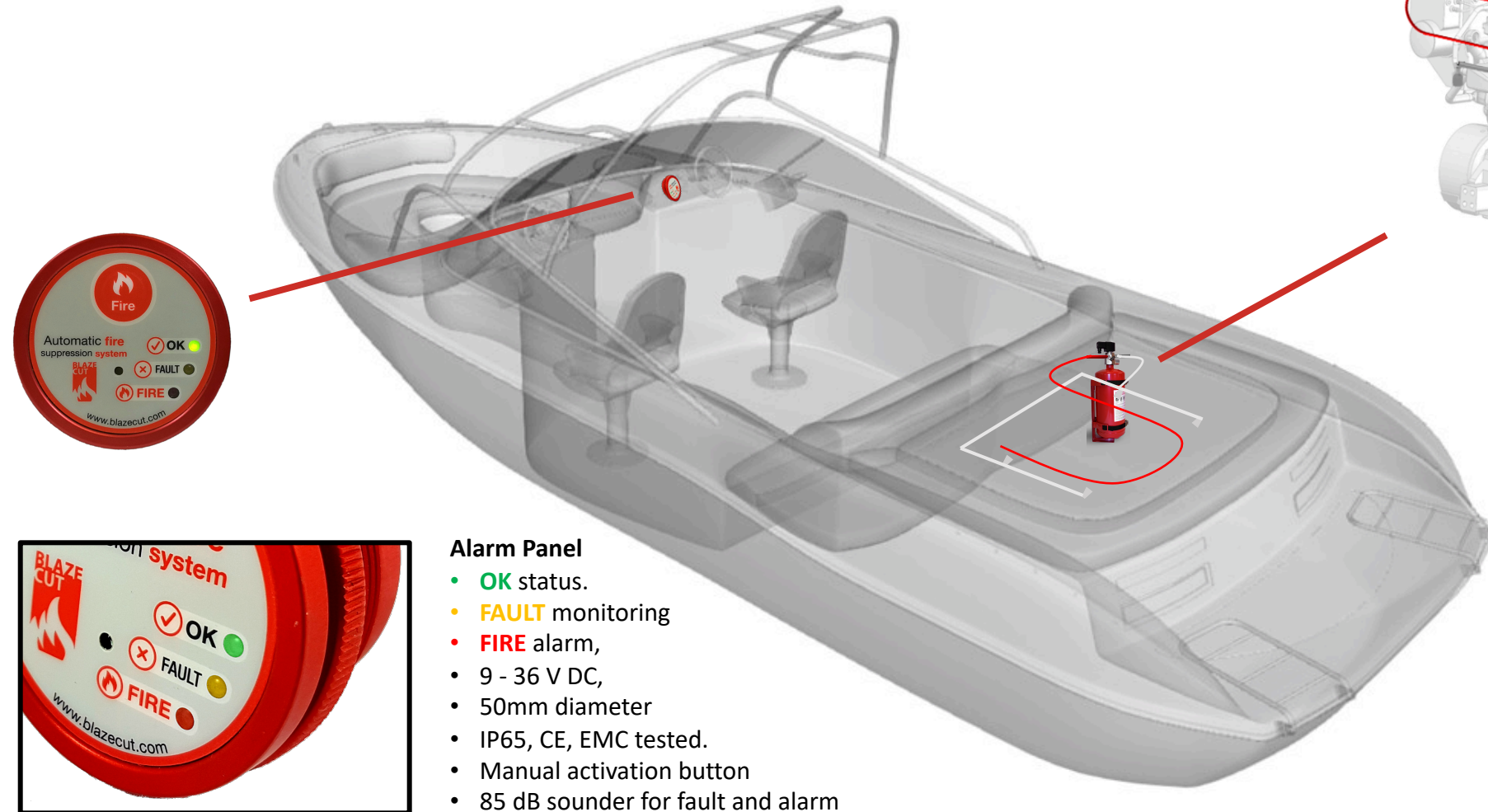

BlazeCut C Series system (ILP)

- Indirect low pressure system
- BlazeTube or BlazeWire Detection
- Powder, gaseous clean agent or foam agent
- Automatic detection
- Manual actuator at driver panel
- Monitored system for faults
- Designed for each application
- Suitable for enclosed engine compartments
- 2 years warranty

Alarm Panel

- **OK** status.
- **FAULT** monitoring
- **FIRE** alarm,
- 9 - 36 V DC,
- 50mm diameter
- IP65, CE, EMC tested.
- Manual activation button
- 85 dB sounder for fault and alarm

Boats and Marine