



BlazeCut
Fire Suppression Systems

www.BlazeCut.com

DRAWING REFERENCE:

T Series Scheme

SYSTEM NUMBER:

T Series 0.25m - 6m

SYSTEM DETAILS:

Customized sizes can be advised at time of inquiry and/or calculated volumes.
Minimum order quantities apply to all custom sizes.

CUSTOMER:

Distributor

DRAWN BY:

Darren Flavel

DATE:

15th February 2022

APPLICATION DETAILS:

Various

NOTES:

None

Pressure Switch APS001 (side view)

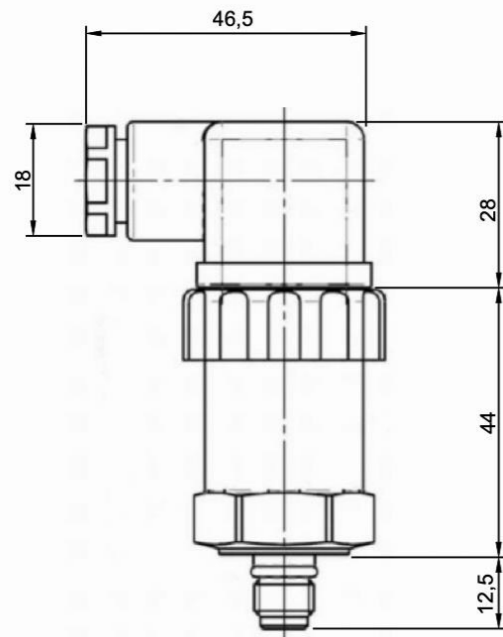

Pressure Switch APS001 (front view)

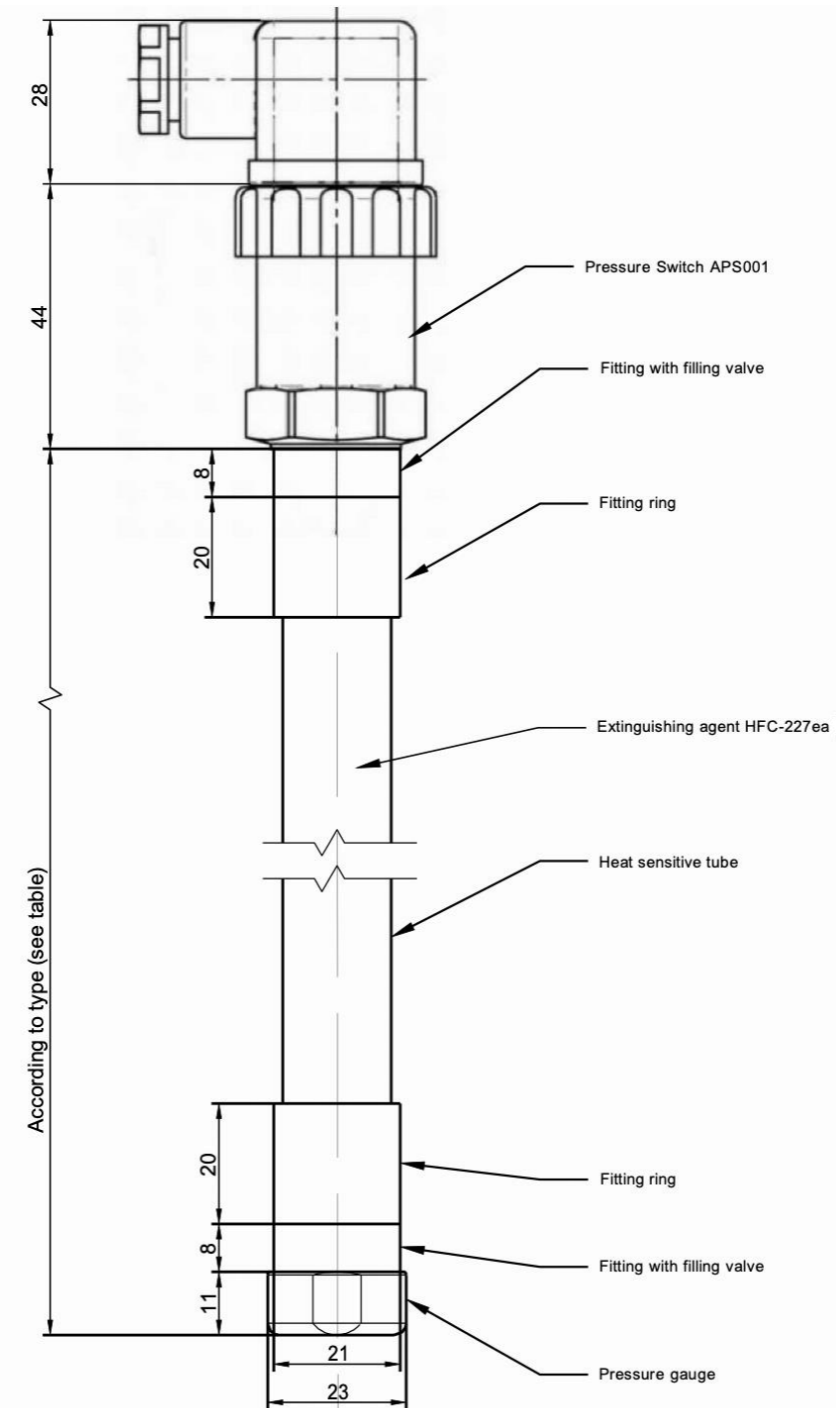
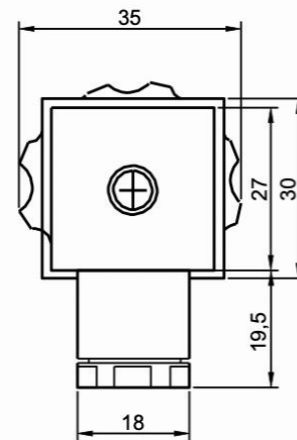

Heat sensitive tube (cross section)

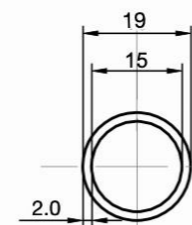

System Type	Type of agent	Amount of agent (g)	Length of system (cm)	Gross weight of system (kg)
T025E	HFC-227ea	50 ± 2	28	0.21
T050E	HFC-227ea	100 ± 2	53	0.29
T100E	HFC-227ea	250 ± 5	113	0.51
T200E	HFC-227ea	500 ± 5	215	0.87
T300E	HFC-227ea	750 ± 10	319	1.23
T400E	HFC-227ea	1000 ± 10	422	1.61
T500E	HFC-227ea	1250 ± 10	526	1.95
T600E	HFC-227ea	1500 ± 10	630	2.32
T025ES*	HFC-227ea	50 ± 2	35	0.34
T050ES*	HFC-227ea	100 ± 2	60	0.42
T100ES*	HFC-227ea	250 ± 5	120	0.64
T200ES*	HFC-227ea	500 ± 5	222	1.00
T300ES*	HFC-227ea	750 ± 10	326	1.36
T400ES*	HFC-227ea	1000 ± 10	429	1.74
T500ES*	HFC-227ea	1250 ± 10	533	2.08
T600ES*	HFC-227ea	1500 ± 10	637	2.45

*including fitted Pressure Switch APS001 with cable plug